

TESLA COIL

500,000 volt lightning Generator

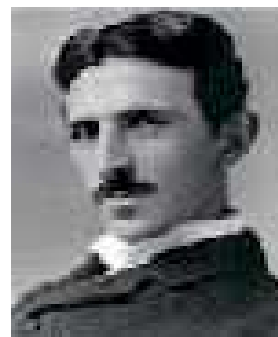

Discover how to build a real Tesla Coil, that can generate lightning. Great many high voltage experiments. These coils are easy to build and will amaze everyone.



500,000-VOLTS OF LIGHTNING

A Lightning Generator Capable of generating small miniature lightning bolts up to 24-in. long. the device is unusually potent considering its overall simplicity and minimal power requirements.

In operation, the Lightning Generator spouts a continuous, crackling discharge of pulsating lightning bolts into the air. These waving fingers of electricity will strike any conducting object that comes within it's range.

A piece of paper placed on top the discharge terminal will burst into flames after a few seconds'of operation, and a balloon tossed near the terminal will pop as though shot down by lightning.

WARNING: You build at your own risk. High voltage is dangerous! use rubber gloves. If you are not familiar with high voltage rules then do not attempt this project until you educate yourself in the use of HV Capacitors and high voltage saftey. See your local library or get a beeginers book on electronics from Radio Shack or any other electronic supplier from the web.

Construction

Building the Lightning Generator is relatively simple. The cost, depending on your scrounge-ability, will be from \$35 to \$80.

Start with L2, the secondary coil, which consists of a 36 1/2-in. length of 1 7/8-in. OD cardboard tubing, wound with a single layer of AWG 30 enameled, copper wire. Choose as perfect a tube as possible and make sure that it is not contaminated with paint or other substances. Heat the tube in an oven to drive out moisture and paint it lightly with varnish or plastic spray.

The coil can be wound by hand or chucked in a slow-turning lathe.

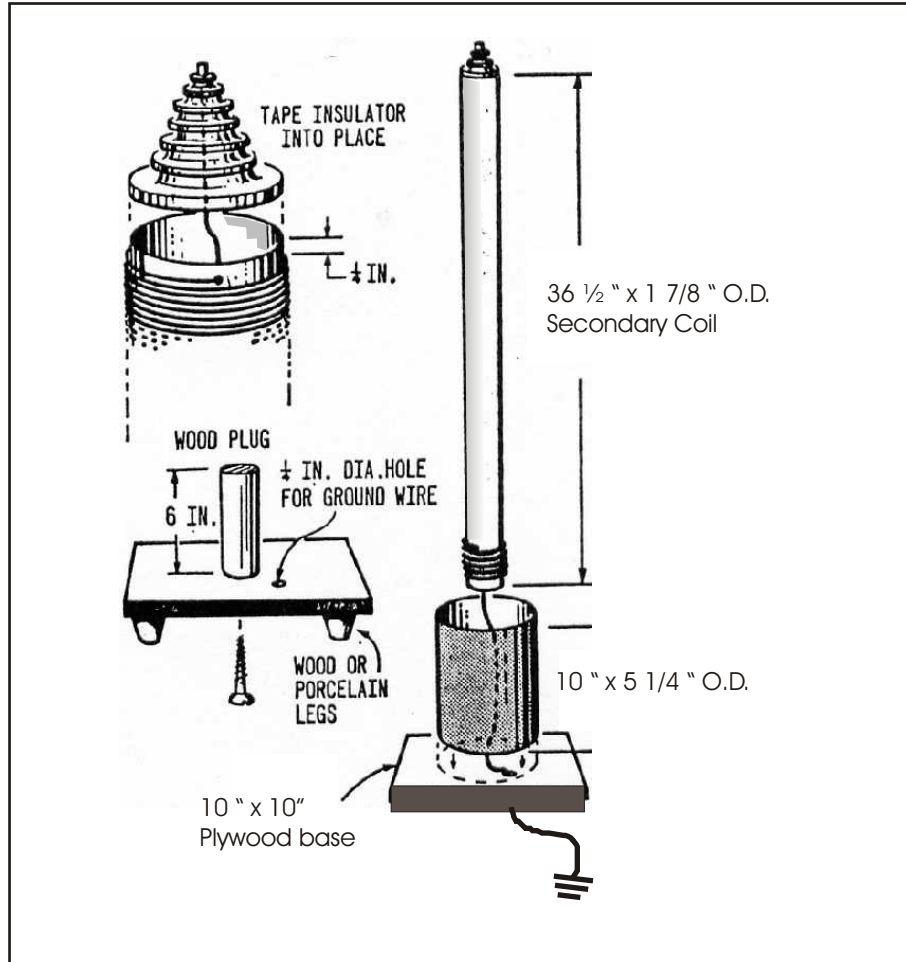

Figure 1-20. Base for coil is made from a 3/4" plywood base

Starting 1/4-in. from the end, begin winding clockwise, making all turns as tight and as close together as possible. Avoid kinks and overlapping.

Total number of turns will be about 3350, but there is no need to keep count since the turns are closely spaced. Leave about two feet

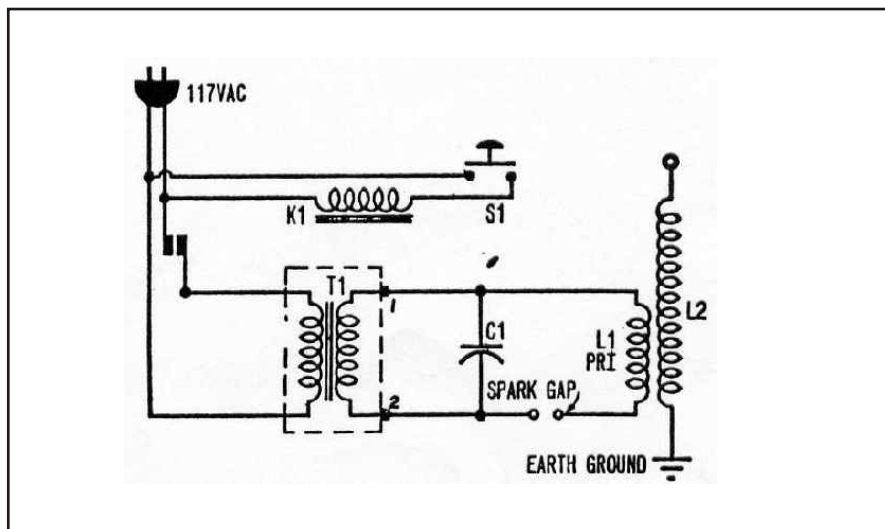

Figure 1-21. This is a Schematic of the entire lightning generator Tesla Coil.

of wire free at the end. Stop winding 1/4 in. from the opposite end of the tube and run a 3-in. length of the wire through a small hole Drilled in the exposed cardboard apparatus.

This end will be the top of the secondary. Apply several coats of varnish to the windings for protection and insulation.

To make the discharge electrode, fit the top of the secondary with a porcelain, center-fed insulator of any type (length should not exceed 3 in.). Insert a bolt through the center of the insulator and attach the 3-in. coil wire to the bottom end of the bolt. No more than 3/4 in. of the bolt should protrude from the insulator top. Fasten the insulator to the end of the secondary coil with electrical tape or other.

Make a wood base for L2 by cutting a 10" square from 3/4 " plywood, and fastening a 6-in. long wooden dowel to the center. Use a 3-in. wood screw to attach the dowel, and, or glue it in place. The secondary should fit snugly over the dowel.

The 2-ft. length of coil wire from L2 can be brought through a 1/4-in. hole drilled in the platform 1 in. from the dowel. another option for the base L2 would be to use 1/2" to 3/4" clear plastic.

Primary coil LI. which fits at the base of the secondary, consists of 28 closely-spaced turns of AWG 8 insulated copper wire on a 10 x 5 1/4 in. Quaker Oats box. or use a 4" PVC pipe. In a pinch, ordinary two-conductor line cord can be used, with the ends twisted together to form one conductor. The box should be varnished and it can be reinforced with a few layers of fiberglass cloth and epoxy resin.

To wind LI, secure the first turn at the bottom of the box with a piece of string, then wind clockwise until 28 turns have been made. Do not wind the entire length of the box, but keep the turns as closely spaced as possible. Secure the last winding with electrical tape.

Cut a hole in the bottom of the box and slip the completed LI over L2, keeping the secondary centered. The exposed cardboard of the

Parts List for Tesla Lightning Generator. Table 1-2.

1. SI-S.p.s.t. pushbutton switch,
2. T1-15,000-volt, 30-mA. neon-sign transformer
3. 1-Spark gap (see text).
4. 1-16 x 20 x 5-in. deep box (plastic or wood-see text)
5. 1-porcelain insulator for discharge terminal.
6. 1-36 1/2x1 7/8-in. OD tube (cardboard, phenolic, or other non-conductor)
7. 1-10 x 5 1/4-in. OD tube (cardboard, phenolic, or other non-conductor-see text)
8. K1-5-amp. contact, 120-volt coil relay (Potter & Brumfield type MR3A or equiv.)
9. L1-38-feet AWG-8 solid insulated wire wound on 5 1/4-in. form.
10. 1-2-1650 feet AWG-30 enameled solid copper magnet wire (approximately a 1/2-lb. spool) wound on 1 7/8-in. form.
11. 3-SAE-30 motor oil, quart cans
12. 8-12 1/4 x 16 1/2 x 1/4-in. sheets of glass (to fit box above-see text)
solder, insulating varnish or epoxy, tape, etc.

primary can be painted with nonconducting enamel or wound with tape.

The Low-Leakage Capacitor

You can build a larger capacitor such as our homemade capacitor designs (see # HVC1 plans) or you can build the following.

You will need a box about 16 x 20 x 5 in. for capacitor C1. A box can be made of 1/4- or 1/2-in. plywood and reinforced with fiberglass. Box size is not critical, though the box must be large enough to hold the capacitor about to be described.

Glass dielectric for the capacitor consists of eight sheets of 16 1/2 x 12 1/4 x 1/4-in. window glass. Cost should run about \$30.

Cut out seven sheets of 20- x 9-in. heavy-duty aluminum foil and assemble C1 as follows: lay a sheet of glass in the box and place a sheet of 20- x 9-in. aluminum foil on the glass as shown in the drawings. Pour in just enough ASA 30 motor oil to cover the foil. On top of this lay another sheet of glass and aluminum foil, but be sure to reverse the tab or free end of foil so that it protrudes from the opposite side of the glass.

Press all air bubbles from between the glass. This done, pour in more oil and continue the process, always alternating each sheet of foil. Bend the foil tabs together on each side of the capacitor in order that wires from the rest of the circuit can be connected to them. About three quarts of oil will be needed for a 16- x 20-in. box. Wooden blocks can be wedged around the plates as a means of keeping them from shifting.

There are a number of ways to make the spark gap, but the best arrangement consists of two 1/2-in. diameter conductors adjustable from 1/4- to 1-in. separation. or try a spark plug.

A simple gap can be made by mounting two 1/2-in. diameter bolts through nuts brazed on 1- x 2-in. metal plates. The plates are mounted on a varnished wood block at least 1 3/4-in. thick to prevent arcing around the gap (see our illustrations).

Power for the circuit is supplied by a **15,000-volt, 30 mA neon-sign transformer**. New transformers cost about \$120 or more-used ones are considerably less.

Wire the circuit with AWG 12 or 14 single-conductor copper wire, as it is stiff enough to be self-supporting. Route all wires separate from each other and other objects, keeping in mind that high voltages will be present throughout most of the circuit. Capacitor C1 is wired into the circuit by attaching wires directly to the aluminum foil tabs. Place components according to drawings.

Operating the Generator

When the circuit is ready for testing, connect the ground wire from the bottom of the secondary to a water pipe or telephone ground

Figure 1-24 Coil L1 is close wound with # AWG-8 copper coated wire. One end of coil connects to spark gap. The other connects to C1 and to T1.

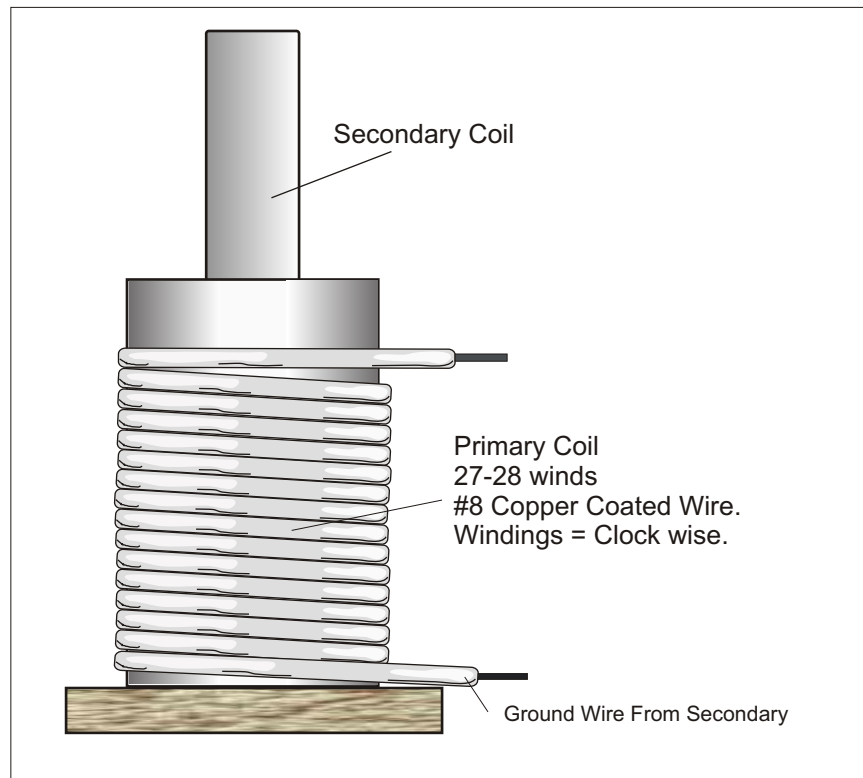

Tuning

If the spark-gap is operating, but either a weak discharge or none at all appears at the top of L2, the coil will have to be tuned. This is accomplished by varying the number or size of the aluminum foil sheets in C1 and by varying the effective turns on L1.

It's easier to begin tuning by varying the exposed area of the top sheet of aluminum foil and by "tapping in" a few turns down from the top of the primary. Maximum discharge generally will be reached with a total variation of no more than two or three turns on coil L1 and one full sheet of aluminum foil in C1.

If reducing the number of turns in L1 and changing the number of plates in C1 doesn't help, try adding several turns to L1 by splicing in additional wire. An additional sheet of foil can be added to the capacitor, but another sheet of glass will be needed also.

It is best not to operate the Generator for more than 15 to 20 seconds continuously without an equal time off, as the oil in the capacitor will start to break down, allowing arcing to occur. But if you build our home made HV capacitors or use an old microwave AC or DC capacitor you will get better results.

Remember to be careful. High voltage can kill and is much more powerful after it enters a large capacitor, wear rubber gloves.

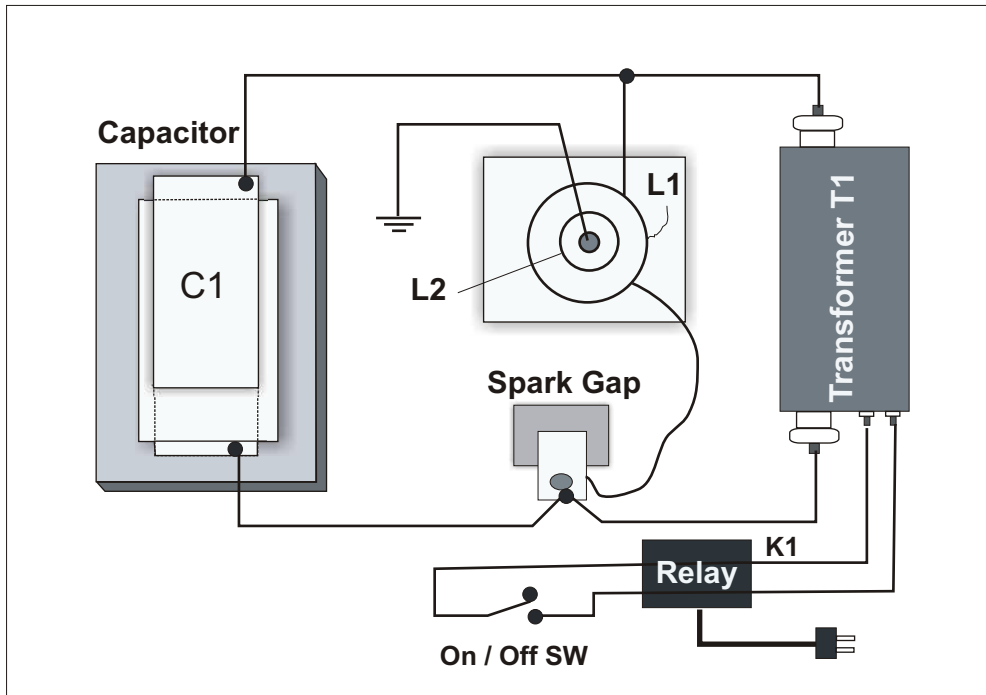

Spark Gap using 2 large copper wires and Electrical box fasteners



You can also use a spark plug or make your own out of wood and 2 separate metals, attach one on top of wood block and one on bottom. Drill 2 holes in each of the metal pieces and place nuts and bolts in them so they can adjust. These are your electrodes.

Experiments

Hold a fluorescent light a few feet from the Generator and throw the switch. The light will glow even though not connected to any electrical source. This is because the high voltage is traveling through the air. Also large, clear light bulbs held near the coil will glow with weird, flowing colors.

Bring a grounded, metal rod within range of the discharge point atop L2 and notice the "bunching" effect as the sparks leave their random pattern and arc to the rod. The discharge will not travel as far to reach a grounded conductor as it will in open air, since the atmosphere itself acts as the opposite electrical pole.

A pinwheel rotor about 6 to 8 in. in diameter can be made from AWG 18 or 20 solid wire and fitted atop the discharge terminal so that it can rotate freely. When the Generator is operating, the rotor will turn from the force of the discharge leaving the ends of the wire.

Place a piece of paper on the terminal and close the switch. In a few seconds, the paper will burst into flames.

Despite the extremely high voltages, the Lightning Generator develops very little current, making a shock from the coil relatively harmless. However, the currents in the rest of the circuit are very dangerous, so they must be treated with respect.

The discharge is virtually impossible to contain. Try inverting a glass tumbler over the discharge electrode; the discharge will pass right through, leaving the glass full of ozone. A heavy, waving arc will easily crackle across a distance of a foot or more to reach a metal rod. To capture the lightning on film, use a camera capable of at least 1/250th sec. shutter speed and try a variety of f-stops.

Balloons can be shot down simply by tossing them at the terminal, and sometimes the effective range of the lightning "anti-aircraft" is surprising.

With reasonable maintenance, the Generator will last indefinitely. Research it and you will discover new experiments and gain insight into the fundamentals of tuned circuits. transmit radio waves to any AM radio etc...

So How Does it Work?

The primary coil L1 and capacitor C1 together form a tuned circuit designed to oscillate at a frequency four times the natural resonant frequency of the secondary coil L2. By inducing current at the base of the secondary L2 equal to a quarter of its natural wavelength, the induced voltage will reach a peak, every half-cycle, at the discharge terminal at the top of L2. The voltage generated is determined by the inductance of L1 and how accurately L1 is tuned.

The spark gap, allows the capacitor to charge to maximum. The spark gap ionizes and the charge stored in the capacitor discharges across the spark gap and most of the charge

stored in the electrostatic field of the capacitor becomes energy in the magnetic field that builds up around LI as the discharge current flows through LI. When CI has discharged to a point where the voltage across CI will no longer sustain an arc across the spark gap, current stops flowing through LI and the magnetic field therefore starts to collapse.

When the magnetic field around LI collapses, it generates a counter EMF (electromotive force) (which also is free energy from a collapsing magnetic field) or voltage that is almost as great as the voltage from T1 that originally charged CI. This voltage breaks down the already partially ionized spark gap and CI begins to charge all over again.

Because of the high inductance and low natural resonant frequency of the secondary winding of T1, this portion of the circuit is effectively nonexistent. Most of the energy pumped into the circuit formed by LI, CI, and the spark gap remains in that portion of the circuit. The secondary of T1 just adds energy every 1/120th of a second. For best results, the oscillation frequency should about 120 kHz.

As CI recharges from the magnetic field around LI, a point is again reached where the spark gap cannot be sustained because all the energy is gone from the winding of LI. This means that the magnetic field has collapsed completely.

Once more CI discharges, and current flow again reverses through the spark gap and a magnetic field builds up around the coil LI. With each cycle of charge and discharge the energy transferred is reduced and would soon die out if energy weren't added by the secondary of T1. This free energy from a collapsing magnetic field can be used to recharge a battery or capacitor bank.

Each buildup and breakdown of the magnetic field induces a voltage in coil L2 which discharges from the tip of L2 in the form of lightning-like flashes and streaks.

Construction Of The Capacitor

Aluminum Foil must be taped to the glass, Foil side up. With tabs protruding from the opposite ends.

In fig. 1- 19 use 8 shts of window glass and seven shts of heavy duty Aluminum foil or roofing foil. Cover each layer with oil. Baby oil, or without.

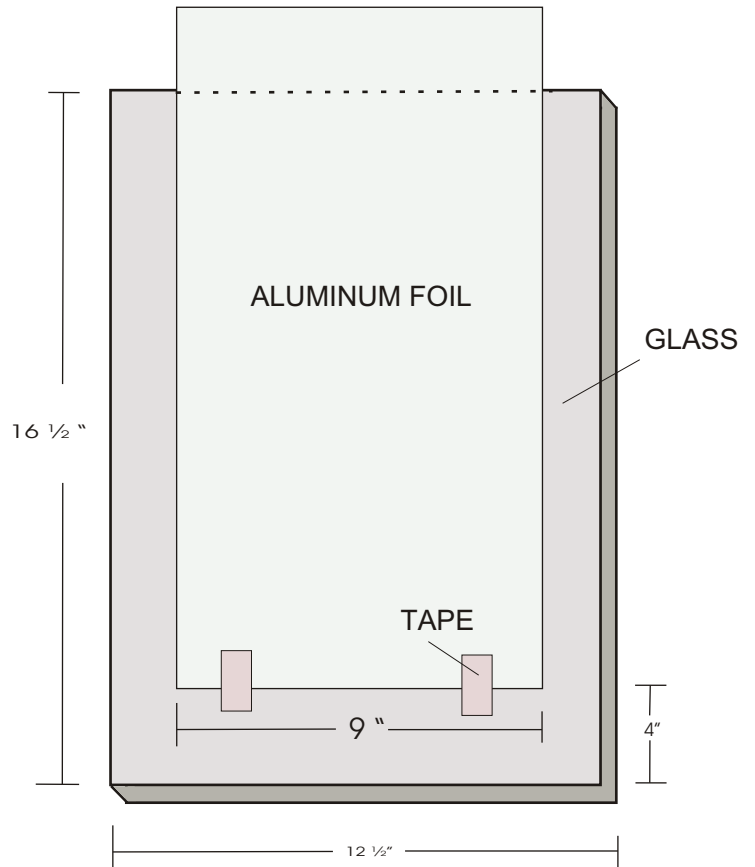

Fig. 1-18 Top View

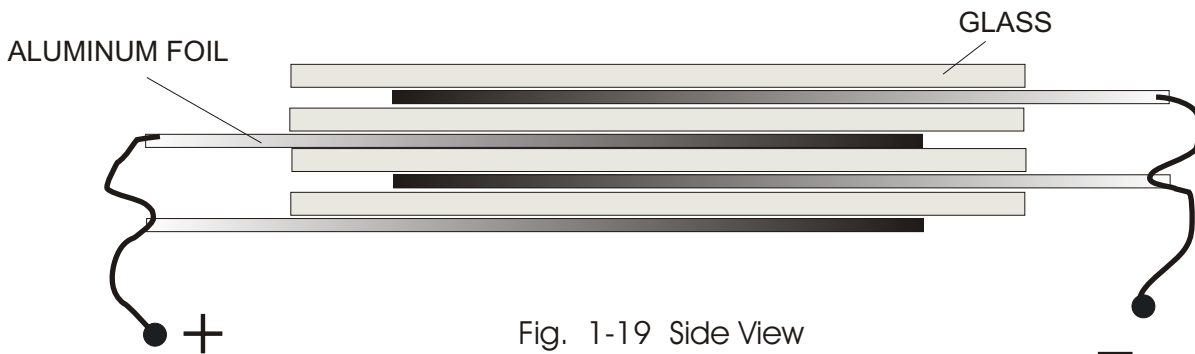
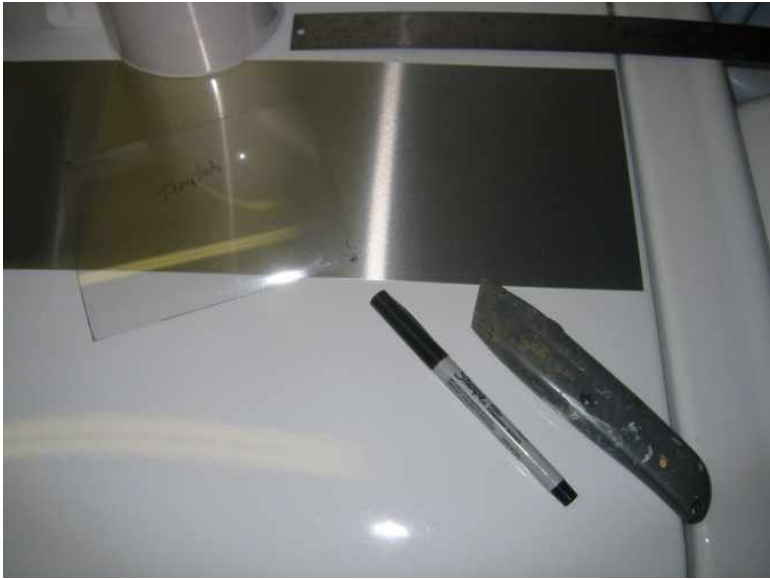
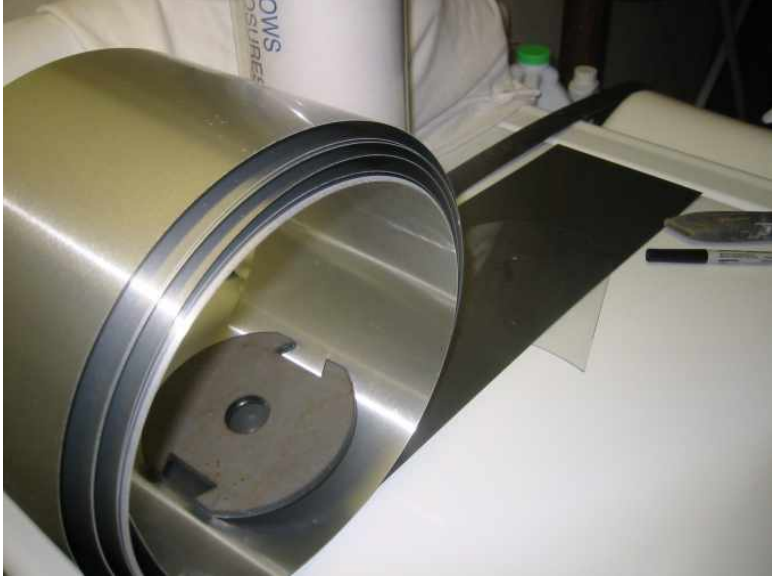

Fig. 1-19 Side View





A multi-stack HV Capacitor
using clear 4 mil mylar.





Tesla Coil using a 4" PVC Pipe



15,000 volt Neon sign transformer



Relay Switches

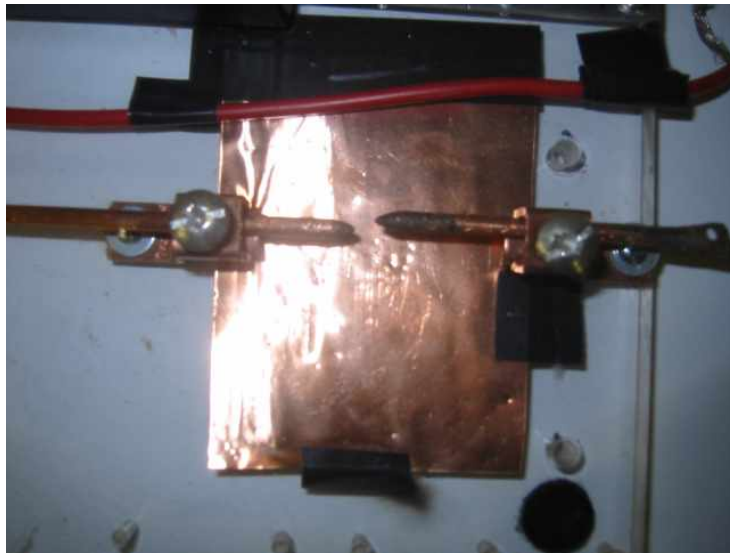

Copper wire Spark Gap